

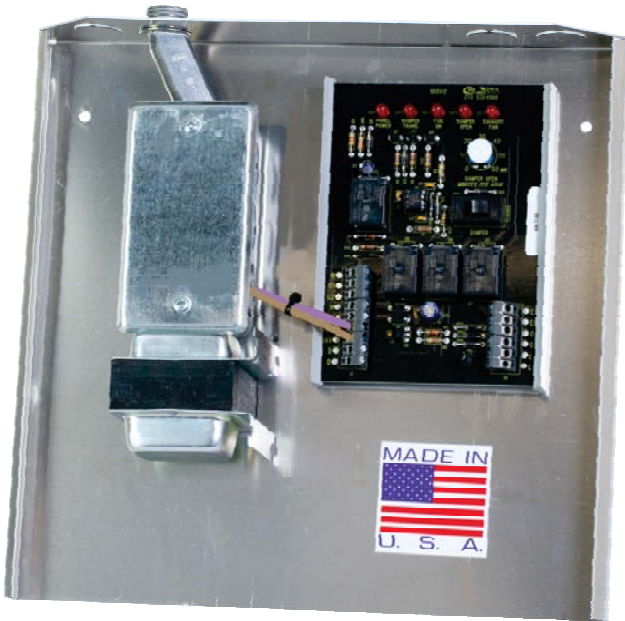

# iO-FAV-ENHANCED AND iO-FAVR-ENHANCED FRESH AIR VENTILATION SYSTEMS INSTALLATION INSTRUCTIONS

The iO-FAV-ENHANCED and iO-FAVR-ENHANCED fresh air ventilation systems are designed to improve residential indoor air quality. This is accomplished by introducing fresh, outside air through an intake damper controlled by a logic panel. The panel controls the amount of fresh air required each hour based on the ASHRAE 62.2 - 2013 Ventilation and Indoor Air Quality Standard.



**iO-FAV-ENHANCED**

The iO-FAV-Enhanced incorporates a built-in transformer to power the outside air damper that is powered open when the panel calls for fresh air ventilation.

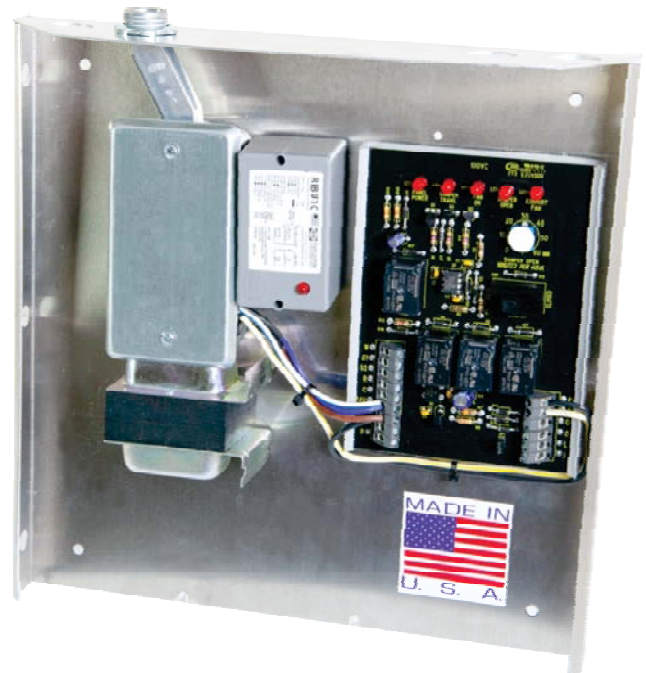

**iO-FAVR-ENHANCED**

The iO-FAVR-Enhanced incorporates a built-in transformer to power the outside air damper plus a relay that can energize a whole house exhaust fan whenever the panel calls for fresh air ventilation.

## INSTALLATION OF INTAKE HOOD, FRESH AIR INTAKE DUCT AND MOTORIZED DAMPER

It is recommended that the intake hood be an open metal type with a screen. The fresh air intake should be located away from dryer or furnace vents, driveways, trash containers, swimming pools and at a level above any expected snow accumulation. Check all local codes that might apply. Depending on the CFM requirement, an insulated 6" or 8" diameter, rigid fresh air intake ducts is recommended with a 6" or 8" diameter, 2-wire, motorized fresh air damper. The damper actuator should be power open / spring return closed.

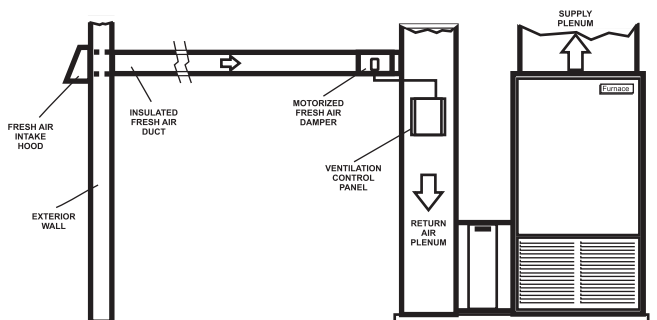

## PANEL INSTALLATION

Remove the panel cover and mount the base to a flat surface in a location that allows easy access and wiring.

## WARNING!

Improper wiring to the HVAC unit can cause damage to equipment and/or the panel. Disconnect electrical power before wiring the panel to the equipment.

# PANEL OVERVIEW

The panel receives its power from the HVAC equipment transformer. The factory mounted 24VAC, 20VA transformer is wired to the 24V terminals and provides power for the fresh air damper.

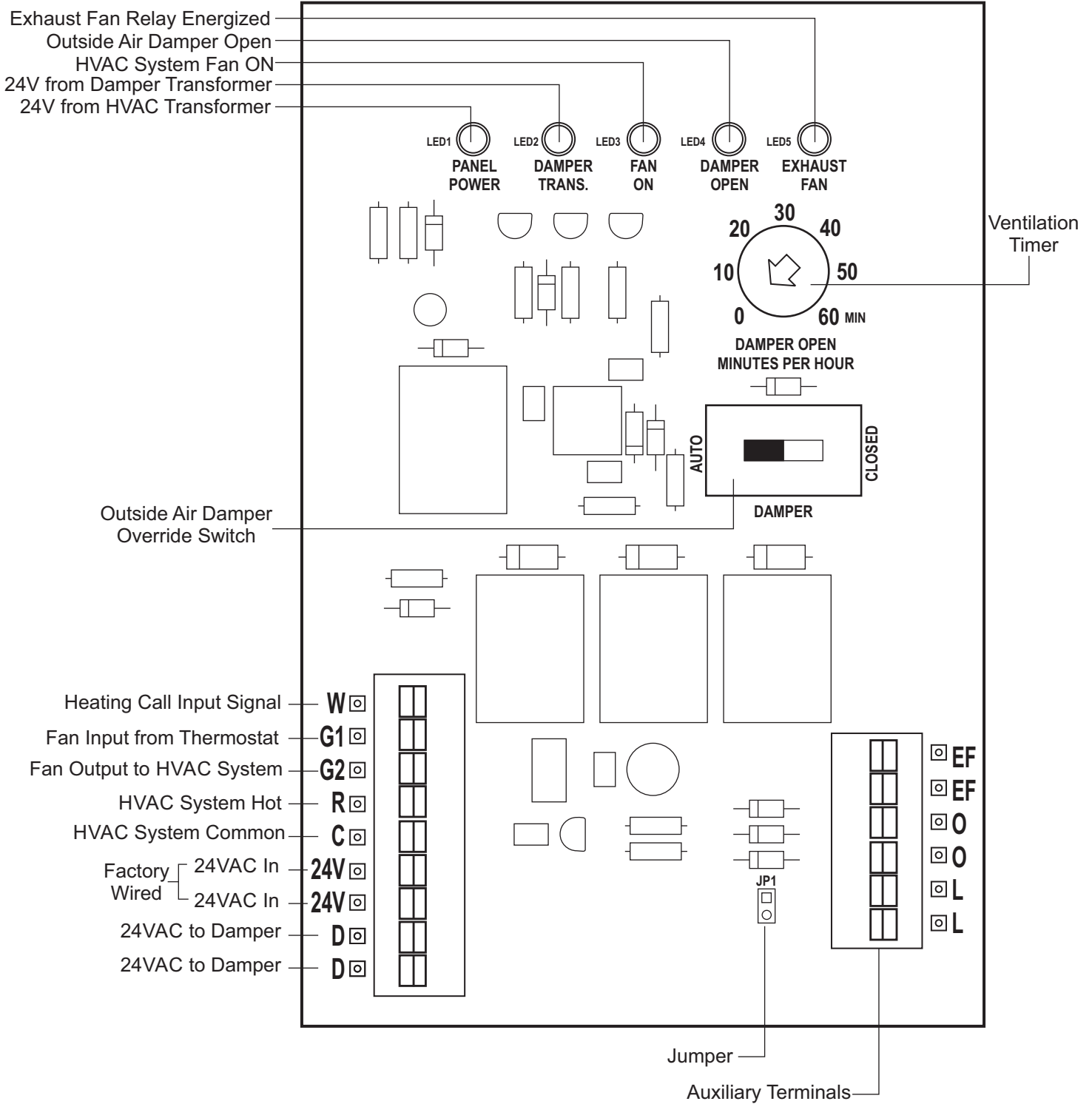

# iO-FAV-ENHANCED 120 VOLT WIRING DIAGRAM

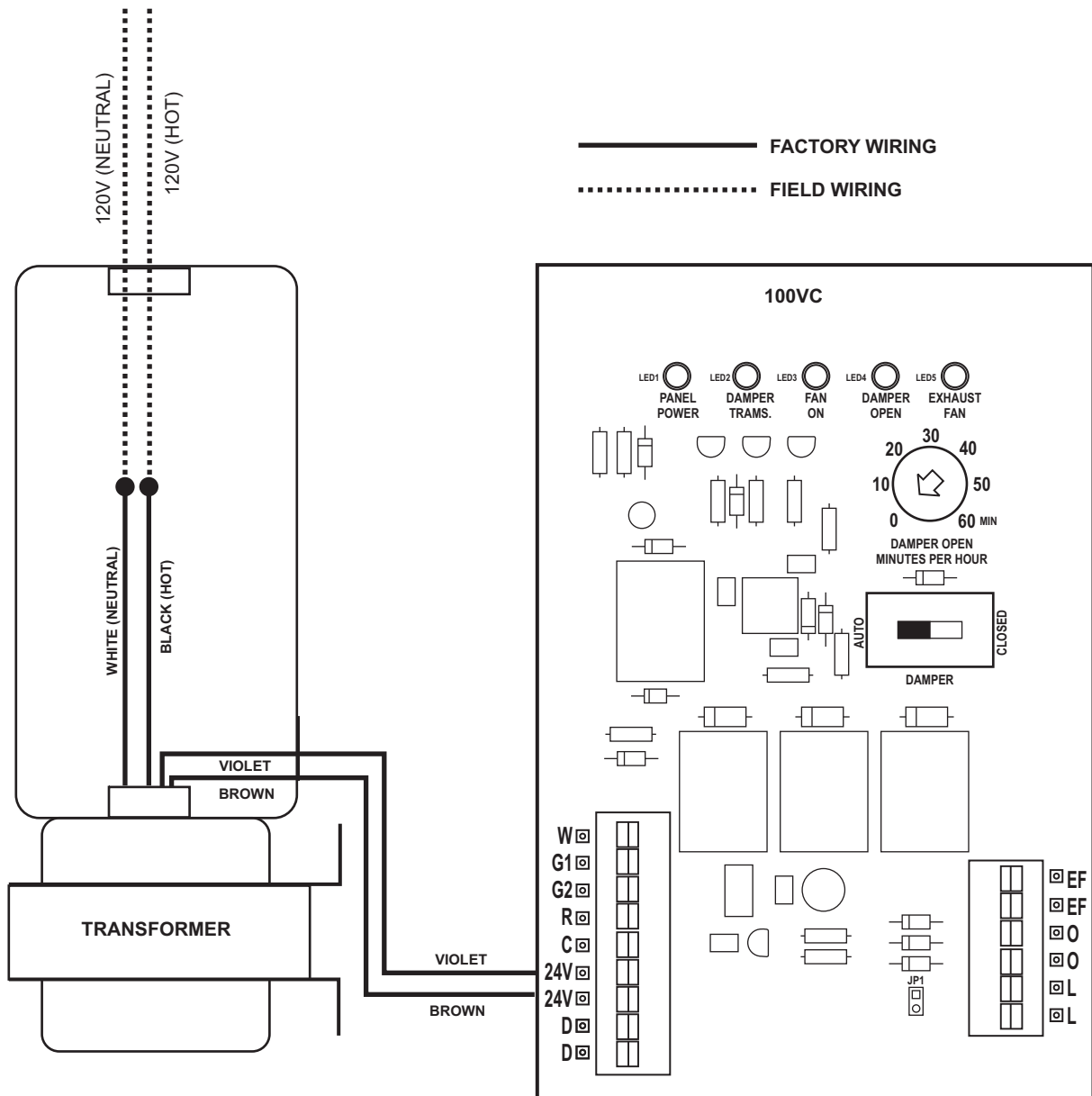

The iO-FAV-ENHANCED has a built-in 24 volt transformer used to power the outside air damper open when the panel calls for ventilation air.

1. Remove the cover on the 2 x 4 junction box.
2. Wire the 120 volt white neutral wire from the transformer to 120 volt primary neutral.
3. Wire the 120 volt primary black hot wire to 120 volt primary hot.

# iO-FAVR-ENHANCED 120 VOLT WIRING DIAGRAM

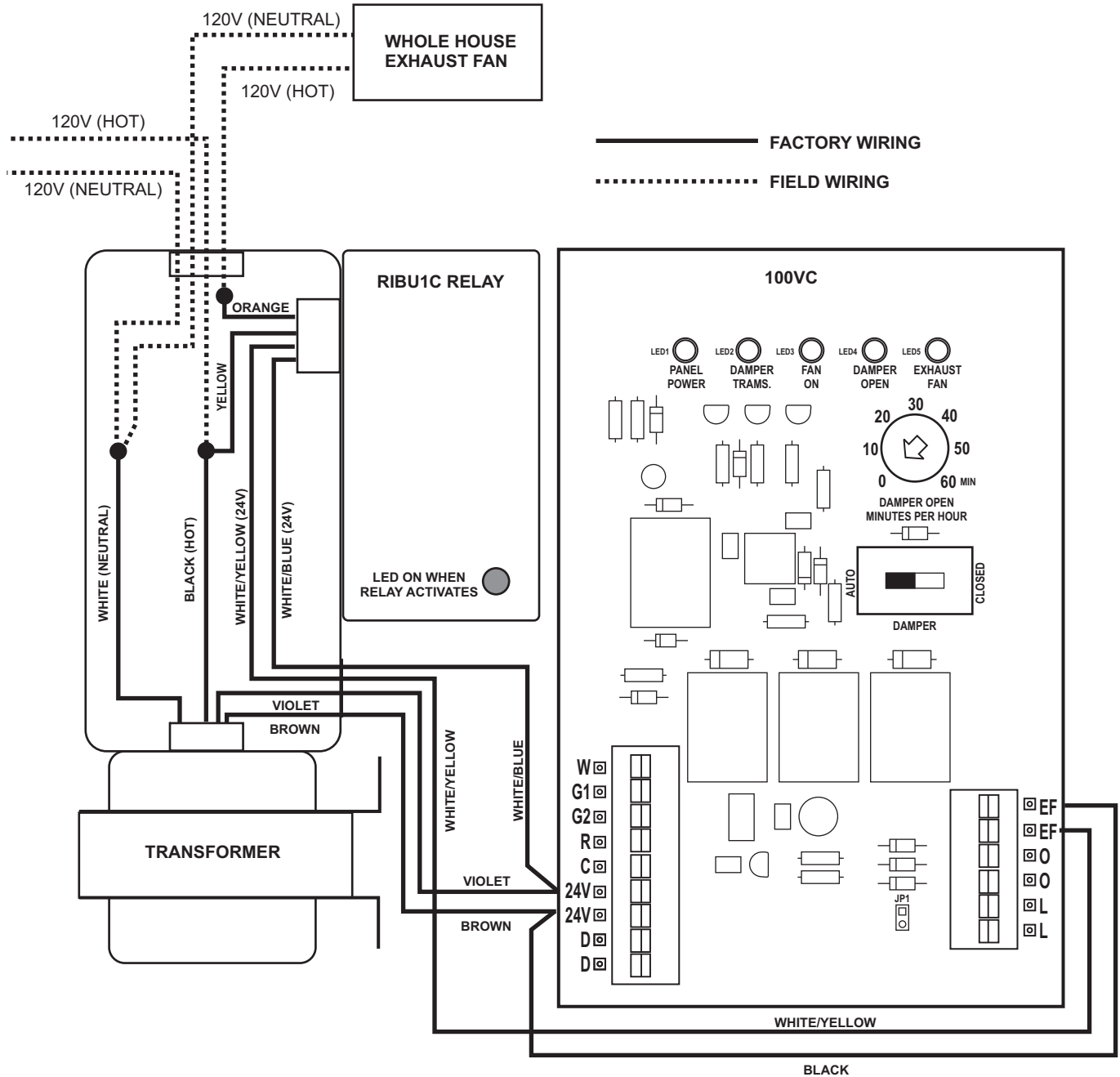

The iO-FAVR-ENHANCED has a built-in transformer used to power the outside air damper open when the panel calls for ventilation air and a relay that allows a whole house exhaust fan to be wired directly to the panel. Whenever the FAVR calls for ventilation air, 24 volts is sent to the relay coil which closes the 120V (Hot) contact to the exhaust fan.

1. Remove the cover on the 2 x 4 junction box.
2. Wire the 120 volt neutral from the exhaust fan and 120V primary neutral to the white neutral wire in the junction box.
3. Wire the 120 volt primary hot wire to the black hot and yellow hot wire in the junction box.
4. Wire the 120 volt hot wire from the exhaust fan to the orange hot wire in the junction box.

# TYPICAL THERMOSTAT AND HVAC EQUIPMENT WIRING

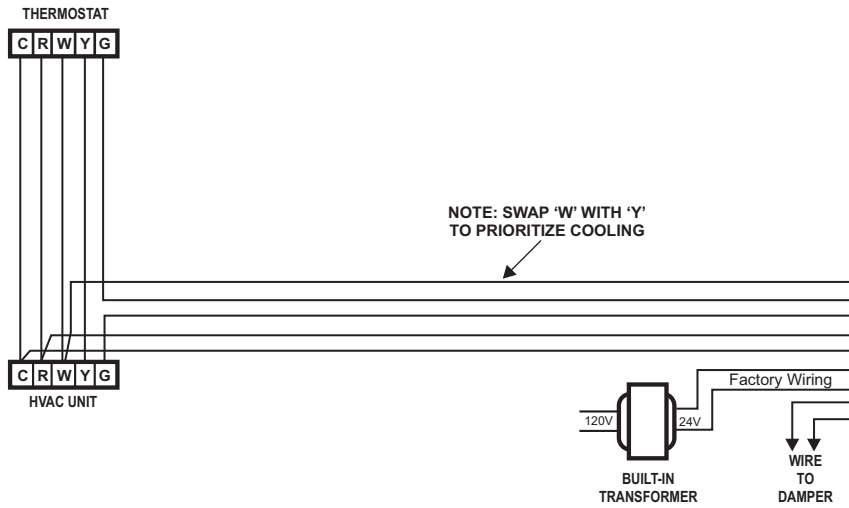

## SINGLE STAGE HEAT/COOL

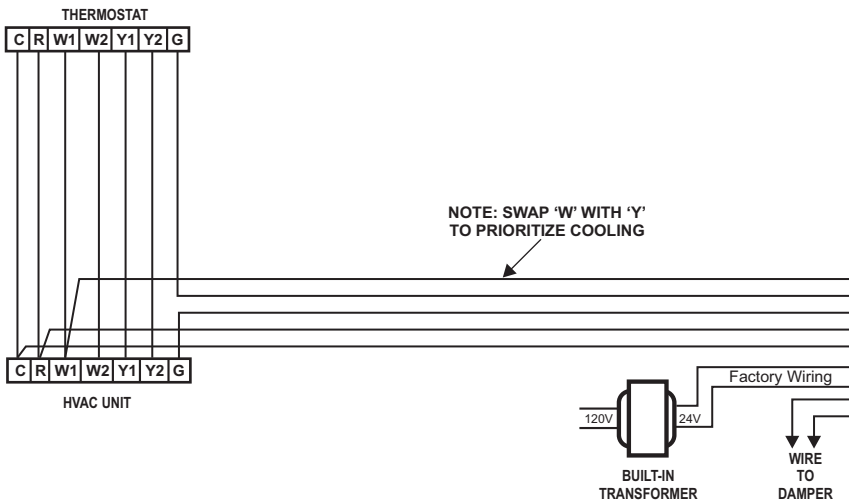
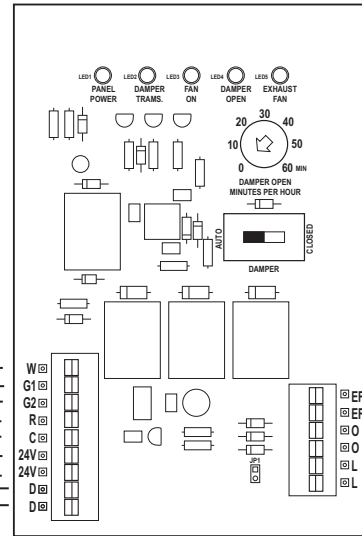

## MULTI-STAGE HEAT/COOL

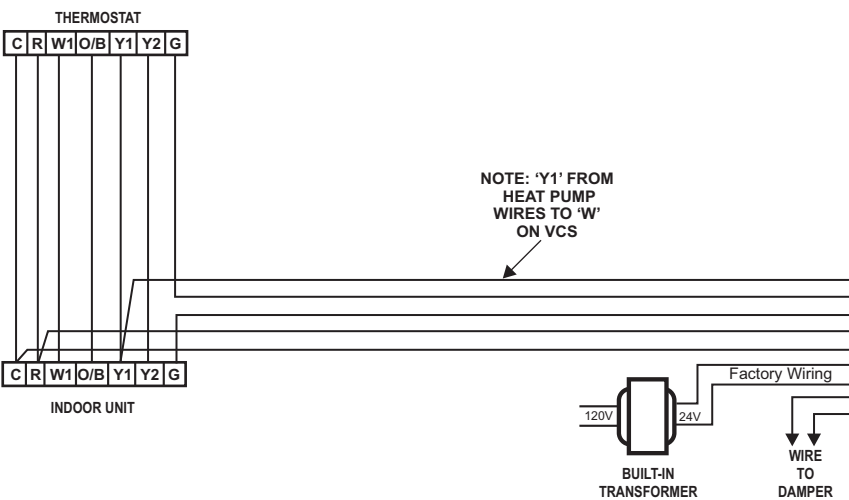
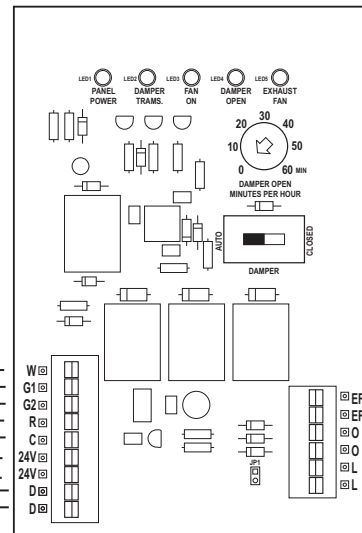

## HEAT PUMP

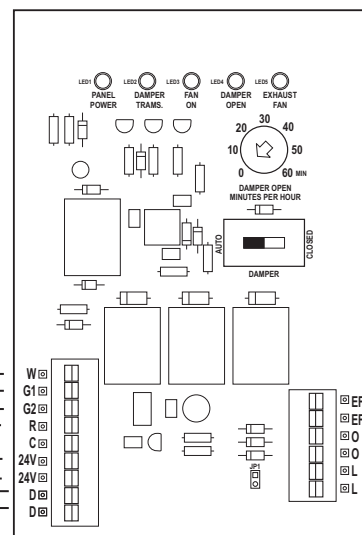

# AUXILIARY TERMINALS WIRING DIAGRAMS

## WIRING TO OPTIONAL EXHAUST FAN

The panel can be wired to an optional exhaust fan using the 'EF' terminals located on the panel. Wire the 'EF' terminals in series with the exhaust fan relay. When the panel is in the AUTO mode, the 'EF' contacts close when the fresh air damper is opened. NOTE: The iO-FAVR-ENHANCED has a built-in relay that is factory wired to the EF terminals.

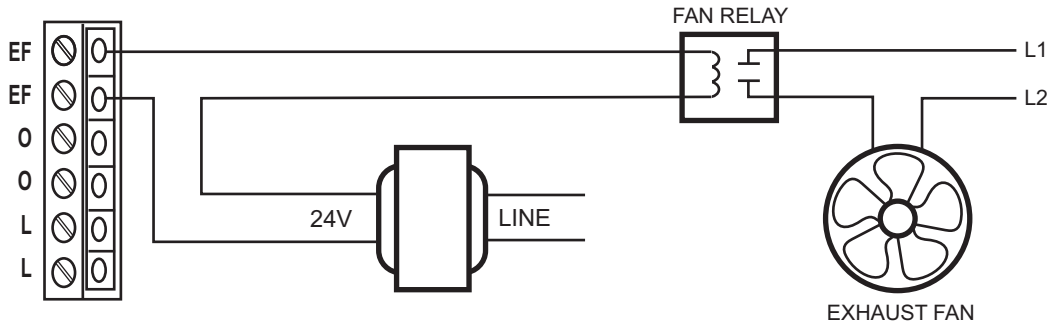

## WIRING TO OPTIONAL DAMPER OVERRIDE SWITCH

The panel can be wired to an optional damper override switch or timer using the 'O' terminals located on the panel. A dry contact closure across the 'O' terminals will open the fresh air damper and bring on the system fan. When the panel is in the damper override mode, ventilation timing and all other override inputs are ignored.

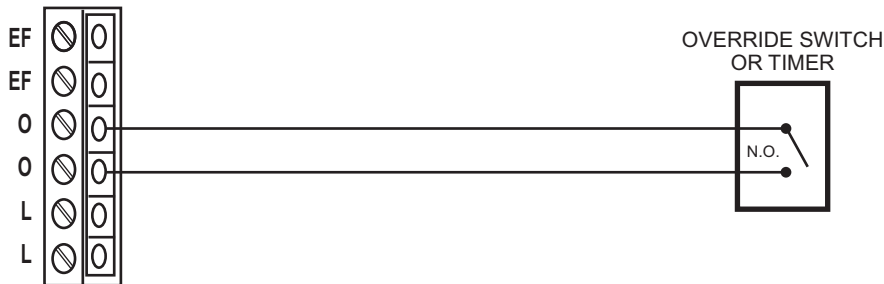

## WIRING TO OPTIONAL OUTDOOR THERMOSTAT AND/OR HUMIDISTAT

The panel can be wired to an optional outdoor thermostat and/or humidistat using the 'L' terminals to prevent the fresh air damper from opening based on a temperature and/or humidity setting. The jumper located to the left of the 'L' terminals must be removed and the outdoor thermostat and/or humidistat wired so that the contacts are closed during normal operation.

For outdoor thermostat installation:

To lockout on high temperature, connect the Blue and Red wires to the "L" terminals. (Black is not used.) To lockout on low temperature, connect the Red and Black wires to the "L" terminals. (Blue is not used)

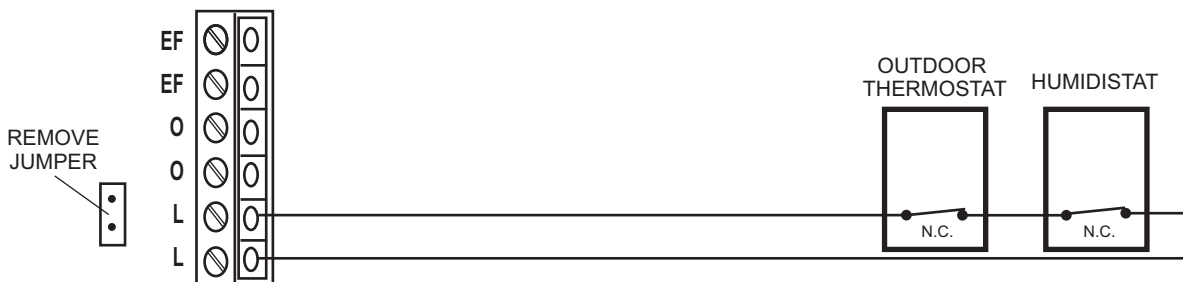

# SEQUENCE OF OPERATION

The ventilation control cycle is divided into two cycles per hour. If the ventilation timer is set for 30 minutes, the panel will cycle the fresh air damper open for 15 minutes during each 30 minute period.

In the heating mode, if there are not calls from the thermostat during the first 30 minute period, the panel will cycle the fresh air damper open and start the fan during the last fifteen minute period.

The same cycle rate pertains to the last 30 minute period which would provide a total ventilation time of 30 minutes out of each 1 hour period. If during the first 30 minute period the thermostat calls for heating, the panel will open the fresh air damper for a maximum time of 15 minutes or until the call is satisfied. If the fresh air damper is open for less than 15 minutes and there are no further calls during the first 30 minutes, the panel will open the fresh air damper and start the fan to complete the ventilation time remaining. The same cycle rate would pertain to the last 30 minute period which would provide a total ventilation time of 30 minutes out of each 1 hour period. In the cooling mode, the panel acts independently of cooling calls (with the exception of heat pumps) but can be wired to prioritize cooling in place of heating.

# TEST, CHECK & STARTUP

To test the FAV functions, power up the panel. Turn the ventilation timer dial clockwise to 60 minutes. All LEDs will light and initiate the system fan, open the fresh air damper and energize the exhaust fan relay through the EF terminals. After testing, reset the ventilation timer using the Quick Reference Chart or Ventilation Formula.

# VENTILATION TIMER QUICK REFERENCE CHART

The reference chart below is designed to provide FAV ventilation timer settings based on using 8" rigid straight duct with friction loss of 0.1" w.g. per 100 ft. This chart can be used for most applications.

VENTILATION TIMER SETTING (MINUTES PER HOUR)						
NUMBER OF BEDROOMS		ONE	TWO	THREE	FOUR	FIVE
HOME SIZE (Ft <sup>2</sup> )	<500	8	10	12	15	16
	501-1000	12	15	16	19	21
	1001-1500	16	19	21	23	25
	1501-2000	21	23	25	27	29
	2001-2500	25	27	29	31	33
	2501-3000	29	31	33	35	37
	3001-3500	33	35	37	39	41
	3501-4000	37	39	41	43	45
	4001-4500	41	43	45	47	49
	4501-5000	45	47	49	51	53

# FORMULA FOR SETTING THE VENTILATION TIMER

The iO-FAV-ENHANCED and iO-FAVR-ENHANCED are designed to simplify selecting the minimum ventilation cycle rate to meet ASHRAE 62.2 - 2013 Standard by using a single dial to set the desired number of minutes per hour that ventilation will take place. The timer cycle rate is calculated as follows:

$$(\text{Home Area in Sq. Ft.} \times 0.03) + ((\text{Number of Bedrooms} + 1) \times 7.5) = \text{Required Airflow in CFM}$$

$$(\text{Required Airflow in CFM} \times 60 \div \text{Total Airflow of Fresh Air Duct}) \times 60 = \text{Ventilation Minutes Per Hour}$$

Example: Home Area = 2,500 Sq. Ft. with 4 bedrooms.  
 $(2,500 \times 0.03 = 75) + ((4 + 1) \times 7.5 = 37.50) = 112.50 \text{ CFM}$

Total airflow of 8" rigid fresh air duct @ 0.1" w.c. = 220 CFM x 60 = **13,200 Cubic Feet Per Hour**

$(112.50 \text{ CFM} \times 60 \text{ Minutes} = 6,750) \quad 6,750 \div 13,200 \times 60 = 30.68 \text{ Ventilation Minutes Per Hour}$

The ventilation timer would be set for **31 Minutes**



[www.iohvaccontrols.com](http://www.iohvaccontrols.com)  
 For Technical Support Call Toll Free: 866-225-5032