



P: 800.961.7370  
www.solerpalau-usa.com

# AUTOMATIC WALL SHUTTER- SINGLE OR DOUBLE PANEL MODEL 556

## FEATURES

### Frame

- .037 gauge galvanized steel.
- Tog-L-Loc and tabbed corners provide rigidity and durability.
- Integrated weather stripping incorporated into frame for additional strength and weather protection.
- Prepunch oblong mounting holes.
- Easy to motorize (optional motor pack model EAS).

### Ratings

- Maximum recommended velocity is 2,500 FPM of free area
- Temperature - -40 F to 180 F

### Options

- Motor packs

## Blades

- 26 gauge 3105 mill finish aluminum.
- Galvanized reinforcement strip across top of blade for added strength and counter balancing and efficiency.
- Felt seal on leading edge of blade for tight closure and quiet operation.
- Flanged ends of blades provide additional weather seal protection.
- Center-mounted galvanized steel tie-rod connects blades for uniform opening and closing.
- 304 stainless steel pivot pins, rivets and bushings.
- Opens freely to allow full 90 degree opening and closing.
- Counter balanced blades allow shutter to be mounted vertically to 45 degrees.

## Single Panel

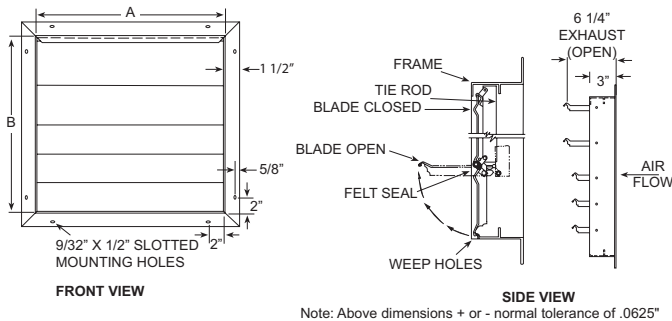

\*Side view of shutter frame and installed motor pack

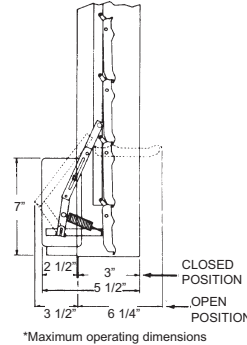

## Double Panel

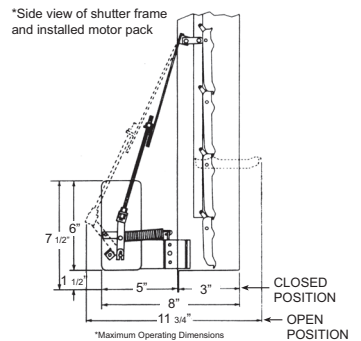
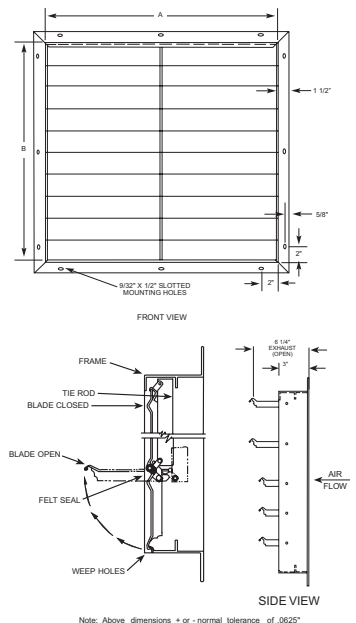

## Dimensions in Inches

Part No.	Inside Frame Dimensions (W x H)	Overall Frame Dimensions (W x H)	Required Hole Opening (W x H)	Face Area (Sq. Ft.)	Est. Free Area (Sq. Ft.)	No. of Panels	Est. Shipping Weight (lbs)
556012	12 x 12	15 x 15	12.5 x 12.5	1.00	.79	1	4.5
556016	16 x 16	19 x 19	16.5 x 16.5	1.78	1.44	1	6.5
556020	20 x 20	23 x 23	20.5 x 20.5	2.78	2.28	1	8.5
556024	24 x 24	27 x 27	24.5 x 24.5	4.00	3.32	1	11
556030	30 x 30	33 x 33	30.5 x 30.5	6.25	5.16	1	15
556036	36 x 36	39 x 39	36.5 x 36.5	9.00	7.44	1	19
556042	42 x 42	45 x 45	42.5 x 42.5	12.25	10.25	2	29
556048	48 x 48	51 x 51	48.5 x 48.5	16.00	12.92	2	35.5

Note: Dimensions are approximate due to normal tolerances in the manufacturing process. Estimated Free Area calculation is based upon the following formula: MD[A+B+ (N x C)]/144. Free Area x FPM = CFM; actual performance may vary.

