

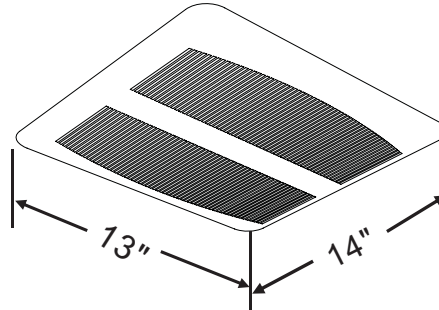

PCLP50, 80, 100

Low Profile Premium Choice

(Low Profile Ceiling or Wall Mounted Ventilation Fans)

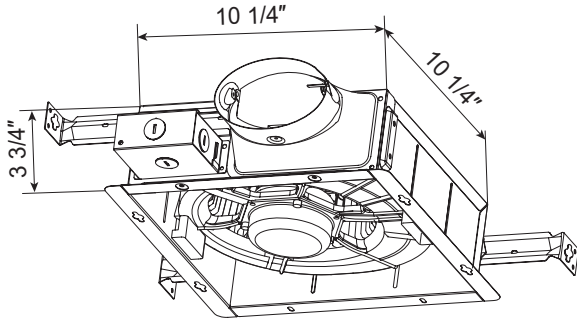

Performance

Model	CFM	Static Pressure (in W.G.)	Watts	Power (V/Hz)	Sones @ 0.1" SP	AMPs
PCLP50	50/35	0.1/0.25	25	120/60	0.4	.35
PCLP80	80/62	0.1/0.25	25	120/60	1.2	.35
PCLP100	100/80	0.1/0.25	25	120/60	2.0	.4

* Energy Star qualified data based on tested air flow and power consumption.



Dimensions

Model	Duct Dia. (oval)	Grille Size (Sq. in inches)	Cabinet Size (in Inches)			Unit Wgt. (lbs)
			W	D	H	
PCLP50	4"	13 x 14	10-1/4	10-1/4	3-3/4	7
PCLP80	4"	13 x 14	10-1/4	10-1/4	3-3/4	7
PCLP100	4"	13 x 14	10-1/4	10-1/4	3-3/4	7

Typical Specifications:

Ventilating fan shall be S&P PCLP50, PCLP80 or PCLP100 low profile fan suitable for ceiling or wall mounting. The fan shall have a 5-year limited warranty. The fan shall be HVI Certified at 0.1 inch water gauge for CFM performance above. The motor shall be ETL and cETL Listed with impedance protection plus additional thermal protection. The fan shall be ENERGY STAR Qualified.

For more information contact us at www.solerpalau-usa.com or 1.800.961.7370 for additional submittal drawings. Soler & Palau will not be responsible for fabrication changes or errors resulting from customer use of a non-current submittal drawing.